

Device Features

- Fully Qualified Bluetooth v2.1+EDR specification System
- Preliminary Support for v2.1
- Best-in-class Bluetooth Radio with +8dBm Transmit Power and -90dBm Receive Sensitivity
- 64MIPS Kalimba DSP Co-processor
- 16-bit Internal Stereo CODEC - 95dB SNR for DAC
- Low-power 1.5V Operation, 1.8V to 3.6V I/O
- Integrated 1.5V and 1.8V Linear Regulators
- Integrated Switched-mode Regulator
- Integrated Battery Charger
- USB, I²C and UART with Dual Port Bypass Mode to 4Mbits/s
- 8Mbits of Internal Flash Memory
- Multi-Configurable I²S, PCM or SPDIF Interface
- Enhanced Audibility and Noise Cancellation
- 7 x 7 x 1.3mm, 0.5mm pitch LFBGA
- Support for IEEE 802.11 Co-existence
- RoHS Compliant

General Description

BlueCore™5-Multimedia Flash is a single-chip radio and baseband IC for Bluetooth 2.4GHz systems.

BlueCore5-Multimedia Flash contains 8Mbit internal Flash memory, which makes it one of the most powerful and flexible Bluetooth audio solutions with the smallest PCB footprint on the market today. When used with CSR Bluetooth stack, it provides a fully compliant Bluetooth v2.1+EDR specification for data and voice.

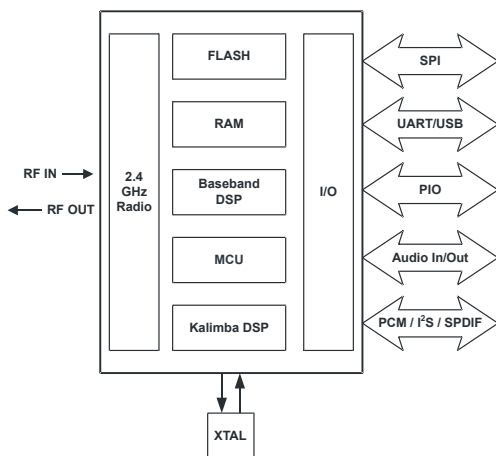

Figure: System Architecture

BlueCore™5-Multimedia Flash Single Chip Bluetooth® v2.1+EDR System

Advance Information

BC57H687B

August 2007

Applications

- Bluetooth-enabled Automotive Wireless Gateways
- High-quality Stereo Wireless Headsets
- High-quality Mono Headsets
- Hands-free Car Kits
- Wireless Speakers
- VOIP Handsets
- Analogue and USB Multimedia Dongles

BlueCore5-Multimedia Flash contains the Kalimba DSP co-processor with double the MIPS and double the memory of BlueCore3-Multimedia, supporting enhanced audio applications.

BlueCore5-Multimedia Flash is designed to reduce the number of external components required which ensures production costs are minimised.

The device incorporates auto-calibration and *built-in self-test*(BIST) routines to simplify development, type approval and production test.

To improve the performance of both Bluetooth and IEEE 802.11b/g co-located systems a wide range of co-existence features are available including a variety of hardware signalling: basic activity signalling, Intel WCS activity and channel signalling.

For additional information refer to the *BlueCore5-Multimedia Flash Performance Specification*

1 Device Details

Radio

- Common TX/RX terminal simplifies external matching; eliminates external antenna switch
- BIST minimises production test time

Transmitter

- +8dBm RF transmit power with level control from on-chip 6-bit DAC over a dynamic range >30dB
- Class 2 and Class 3 support without the need for an external power amplifier or TX/RX switch

Receiver

- Receiver sensitivity of -90dBm
- Integrated channel filters
- Digital demodulator for improved sensitivity and co-channel rejection
- Real-time digitised RSSI available on HCI interface
- Fast AGC for enhanced dynamic range

Synthesiser

- Fully integrated synthesiser requires no external VCO, varactor diode, resonator or loop filter
- Compatible with crystals between 12 and 52MHz or an external clock
- Accepts 7.68, 14.44, 15.36, 16.2, 16.8, 19.2, 19.44, 19.68, 19.8 and 38.4MHz TCXO frequencies for GSM and CDMA devices with sinusoidal or logic level signals

Baseband and Software

- Internal 8Mbit Flash
- Internal 48Kbyte RAM, allows full-speed data transfer, mixed voice/data and full piconet support
- Logic for forward error correction, header error control, access code correlation, CRC, demodulation, encryption bit stream generation, whitening and transmit pulse shaping
- Transcoders for A-law, μ -law and linear voice from host and A-law, μ -law and CVSD voice over air

Physical Interfaces

- Serial peripheral interface* (SPI) with clock speeds up to 64MHz in Master mode and 32MHz in Slave mode.
- Optional I²C compatible interface (master/slave)
- Two UART interfaces with programmable data rate up to 3Mbits/s with an optional bypass mode
- Full speed USB v1.1 interface
- Bi-directional serial programmable audio interface supporting PCM, I²S and SPDIF formats
- Two LED drivers with faders

Kalimba DSP

- Very low power Kalimba DSP co-processor, 64MIPS, 24-bit (or 16-bit) fixed point core
- SBC decode takes approximately 4mW power consumption while streaming music
- Single-cycle MAC; 24 x 24-bit multiply and 56-bit accumulator
- 32-bit instruction word, dual 24-bit data memory
- 24Kbyte (6Kword) program RAM, 36Kbyte + 48Kbyte (16Kword + 12Kword) data RAM
- 64words x 32-bit program memory cache when executing from Flash or SDRAM

Stereo Audio CODEC

- 16-bit internal stereo CODEC
- Dual ADC and DAC for stereo audio
- Integrated amplifiers for driving 16 Ω speakers; no need for external components
- Support for single-ended speaker termination and line output
- Integrated low-noise microphone bias
- Standard sample rates of 8kHz, 11.025kHz, 16kHz, 22.05kHz, 32kHz, 44.1kHz and 48kHz (DAC only)

Auxiliary Features

- User space on processor for customer applications
- Crystal oscillator with built-in digital trimming
- Power management includes digital shutdown and wake up commands with an integrated low power oscillator for ultra-low power Park/Sniff/Hold mode
- Clock request output to control external clock
- On-chip regulators: 1.5V output from 1.8V to 2.7V input and 1.8V output from 2.7V to 4.5V input
- On-chip high-efficiency switched-mode regulator; 1.8V output from 2.7V to 4.4V input
- Power-on-reset cell detects low supply voltage
- 10-bit ADC and 8-bit DAC available to applications
- On-chip charger for lithium ion/polymer batteries

Bluetooth Stack

CSR's Bluetooth Protocol Stack runs on the on-chip MCU in a variety of configurations:

- Standard HCI (UART or USB)
- Complete stack and application running on chip
- Audio CODEC and echo-noise suppression or customer-specific algorithms running on the DSP

Package Options

- LFBGA 120-ball, 7 x 7 x 1.3mm, 0.5mm pitch

2 Ordering Information

Interface Version	Package			Order Number
	Type	Size	Shipment Method	
UART and USB	LFBGA 120-ball (Pb free)	7 x 7 x 1.3mm, 0.5mm pitch	Tape and reel	BC57H687B-ITM-E4 ^(a)

^(a) Until BC57H687B reaches **Production** status, engineering samples order number applies. This is BC57H687B-ES-ITM-E4, with no minimum order quantity.

Note:

At **Production** status **Minimum Order Quantity** is 2kpcs taped and reeled.

Document History

Revision	Date	Change Reason
Issue	10 AUG 07	Original publication of this document Send feedback on this document to Comments@csr.com